

# **DARLINGTON NGS VACUUM BUILDING OUTAGE: MODIFICATION TO SUPPLY POST-SEISMIC MAKEUP WATER TO THE HEAT TRANSPORT SYSTEM**

**D. Li, B. Dean and M. Emad**

Wardrop Engineering Inc, a Tetra Tech Company, Energy Division  
Pickering, Ontario, Canada

## **Abstract**

The periodic stationwide outage at Darlington NGS includes removal of the Emergency Coolant Injection System from service to allow for maintenance. As a prerequisite, the station must set up a minimum 2.5 kg/s temporary makeup water supply, to help cool the fuel should a seismic event occur. This modification cannot be commissioned, as commissioning would dilute the heavy water in the Primary Heat Transport System with light water. Therefore, flow analysis is necessary to demonstrate that the required flow rate can be achieved. This paper provides details of the design, and key aspects of the supporting analysis.

## **1. Introduction**

The periodic stationwide outage at Darlington NGS includes a 5-day period in which the Emergency Coolant Injection System (ECIS) will be taken out of service, to allow maintenance to be done to parts of the system that cannot be maintained while the system is in service. Since one of the functions of the ECI System is to provide emergency makeup cooling to the Primary Heat Transport System (PHTS) following a seismic event, the station is required to install a temporary connection that can provide an alternative supply for this scenario while the ECIS is out of service. This paper describes the modification developed to set up the alternative supply. The modification is critical to the outage, but cannot be field tested, as commissioning would dilute the heavy water in the PHTS with light water. Thus, flow analysis is critical in providing assurance that the design requirements will be met. Details of the design and key aspects of the supporting analysis completed by Wardrop Engineering Inc. (WEI) and Ontario Power Generation (OPG), are described below.

### **1.1 Plant description**

Darlington Nuclear Generation Station (DNGS) is a nuclear facility in operation since 1993. It is comprised of 4 CANDU reactors (Units 1 to 4) with a total capacity of 3500 MWe. The reactors are natural uranium dioxide fuelled pressurized heavy water reactors. DNGS is owned and operated by Ontario Power Generation (OPG).



Figure 1: Darlington NGS

## 1.2 Station Containment Outage and Vacuum Building Outage description

DNGS has a station-wide Containment System. The Containment System is one of four Special Safety Systems and is composed of a number of systems and subsystems whose collective purpose is to prevent a significant release of radionuclides to the outside environment. The containment envelope is formed by a number of major structures, including the four Reactor Vaults, East and West Fuelling Facilities Auxiliary Areas, a Vacuum Structure, a Pressure Relief Duct, and a Pressure Relief Valve Manifold, as shown in Figure 2 [1].

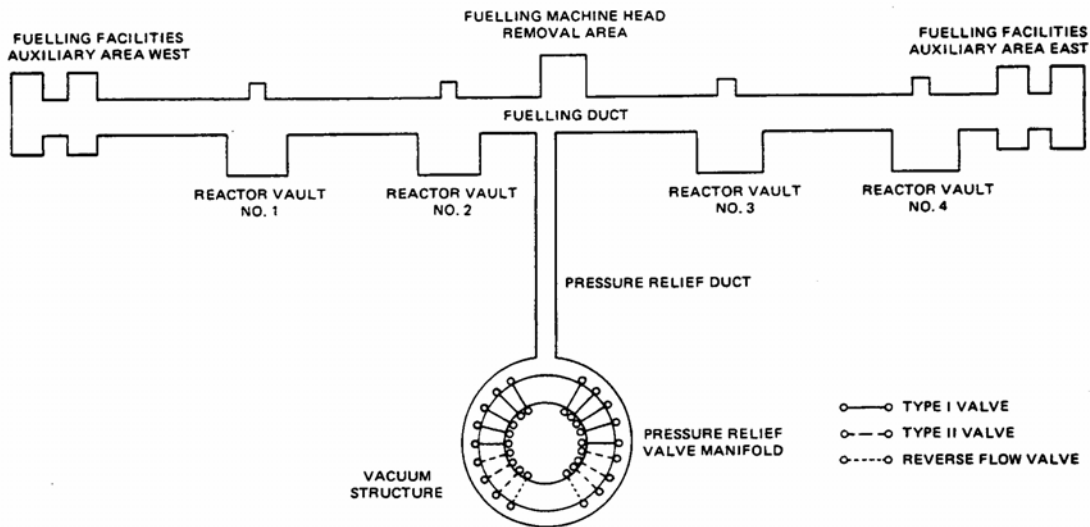

Figure 2: Darlington Containment System

The Containment System must be inspected for integrity and leak-tightness every 6 years during a Station Containment Outage (SCO). Every 12 years, the SCO becomes a Vacuum Building Outage (VBO), during which the Vacuum Structure must also be tested. A VBO is

planned for 2009. The last SCO at Darlington was completed in the fall of 2003, and the last VBO in the spring of 1997.

During an SCO or VBO, the entire station is shut down to allow key station systems to be taken offline for maintenance. Many of these are safety-related systems that must remain in service if any of the reactor units is running. The Emergency Coolant Injection System is one such system. Even during a station outage the ECIS has a safety role; this must be supplied by alternative means before the system can be removed from service.

### **1.3 ECI System description**

The Emergency Coolant Injection System (ECIS) is a Special Safety System. It has no role during normal operation, but is poised ready to inject light water into the Primary Heat Transport System (PHTS) should an accident occur which requires coolant makeup beyond the capacity of the Heat Transport Pressure and Inventory Control System [2].

The ECIS automatically provides makeup cooling water to the PHTS following a postulated Loss of Coolant Accident (LOCA). The ECIS is designed to serve all four reactor units of the station. The system consists of a common portion, located in the Central Service Area (CSA), and four unitized portions, each serving an individual reactor unit. The common portion of the ECI System contains the Injection Water Storage Tank (IWST), low pressure and high pressure pumps, warming circuit and the recovery sump. The unitized portions consist of the piping and valves for delivery and injection of the water.

One of the scenarios for which the ECIS may be required to supply makeup water is following a seismic event (see Section 2.1 for further discussion). Therefore, even if all other conditions allowing ECIS removal from service are met, the system cannot be taken offline until an alternative source of post-seismic makeup water is established.

### **1.4 PHT System description**

Coolant (heavy water) is circulated through the Primary Heat Transport System (PHTS) of each reactor unit at all times during reactor operation, shutdown, and maintenance. The ECIS provides emergency coolant flow (light water) to the fuel if the normal reactor coolant is lost. The PHTS consists of two loops. Each loop contains 2 pumps, 2 steam generators, 2 reactor inlet headers, 2 reactor outlet headers, and 240 sets of inlet and outlet feeders (one for each of 240 reactor fuel channels). Each loop removes the heat from half of the 480 channels in the reactor core. A simplified schematic of the PHTS circulation, showing ECI tie-in points, is shown in Figure 3.[3]

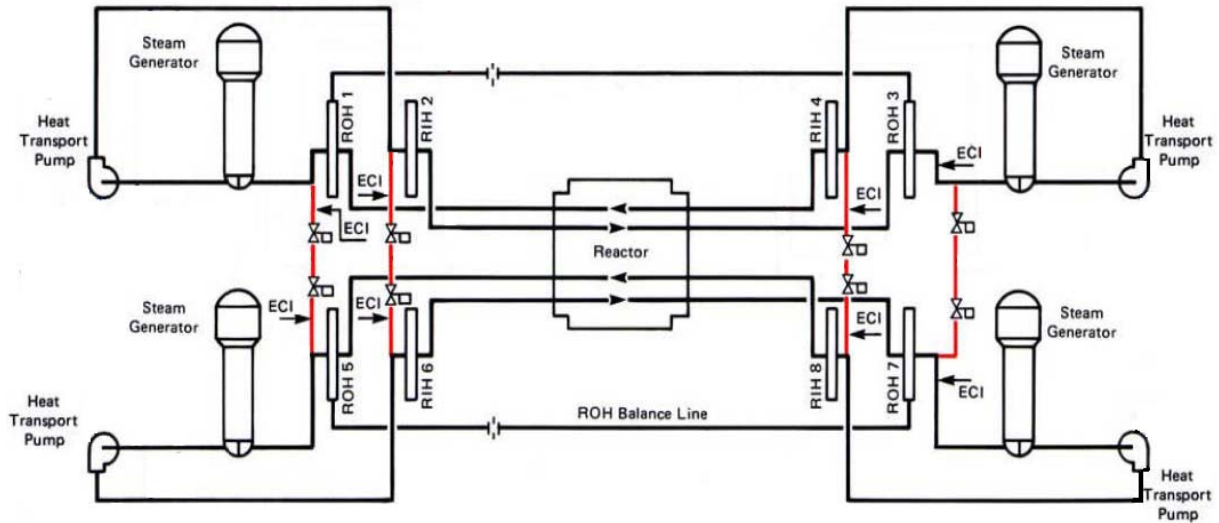

Figure 3: Simplified Schematic of Main Heat Transport Circuit

### 1.5 Design Basis Earthquake (DBE) description

The Design Basis Earthquake (DBE) is defined as a representative earthquake that certain key station systems must be designed for. It is an engineering representation of the combined effects of the free-field seismic motion, and is based on a statistical analysis of 800 earthquakes in Eastern Canada. The DBE for the Darlington site encompasses all possible effects of a magnitude 5 mid-crustal depth earthquake at 20 km (Richter Scale), a magnitude 6.5 earthquake at 110 km on the south shore of Lake Ontario and a magnitude 6.7 earthquake at a distance of 200 km in Eastern Ontario. Certain station systems and structures are seismically qualified to provide high confidence that the following nuclear safety capabilities remain available following a DBE:

1. Ability to shut down the reactor
2. Ability to ensure the reactor remains shut down
3. Ability to remove decay heat
4. Ability to limit radioactive releases
5. Ability to monitor the status of the steam supply system [4].

### 1.6 Modification requirements

The proposed alternative source of post-seismic makeup water is the Emergency Service Water (ESW) System. A temporary modification is needed to establish the flowpath required to set up this alternative supply. Although the ECIS pumps are not in service and the system is depressurized during its outage window, the ECIS piping is available to establish the flowpath from the ESW System to the PHT System and may be used for the modification.

This modification will consist of hoses routed to provide a flowpath for the makeup water, and will be staged (i.e. laid out but not connected) prior to the ECIS Outage. The modification will not be commissioned, as commissioning would dilute the heavy water in the Primary Heat Transport System with light water. Thus, the station must rely upon flow analysis to provide assurance that the flow requirements will be met.

The modification is required to supply a minimum 2.5 kg/s makeup water from the ESW System to the PHT system within 55 minutes (further discussed in section 2.1) and must ensure that there is no backflow from the ECIS or PHTS to the ESW System. The temporary line connections and supports must be qualified to maintain their integrity and functionality following a Design Basis Earthquake.

It is also important for the modification to be located in an area that will be accessible following a seismic event, as operator access is required for manual connection of the tie-in points to establish the makeup water supply. The layout must be such that Maintenance and Operations personnel will not be endangered, and such that failure of any non-seismically qualified systems, will not adversely affect the operation of the temporary modification [5].

## **2. Analysis**

Analytical methods were used to determine parameters such as:

- Required flow rate of makeup water
- Post seismic pressure at the reactor header (point of delivery)
- Post seismic pressure at the ESW tie-in point (source of makeup water)
- Predicted flow rates of candidate designs
- Effect of added weight on seismic qualification of the ESW and ECI Systems.

### **2.1 Makeup water requirement**

The required flow rate of makeup water is a factor in the determination of the available ECI recall time following a seismic event. The ECI recall time (i.e. the time by which the ECIS must be back in service) is defined as the time that elapses before the coolant level falls to 10 cm above the centerline of the reactor headers [6]. The latest determination of recall time is 55 minutes (without the modification in place). Therefore, this was established as the time available to place the modification in-service following a seismic event [5].

During the ECIS outage, the primary heat sink will be provided by the Shutdown Cooling (SDC) System, with Natural Circulation designated as the backup to prevent pressurization of the PHTS. For Natural Circulation to be effective, the feeder connections in the reactor headers must be covered with liquid. Assuming that work requiring draining below the feeder connections does not occur during the ECI outage, a DBE is the only scenario that could result in draining below this level.

Since the ECIS and PHTS are both DBE qualified, an earthquake will not cause a Loss of Coolant Accident (LOCA). However, as a conservative measure, the potential for small leaks (equivalent to a 1 in<sup>2</sup> hole) in the main heat transport circuit following a DBE is being taken into account.

To determine the potential consequences of such small leaks, mass and energy balances of the steam generator, moderator, end shields, and primary heat transport systems were completed by OPG [6]. The conclusion of these analyses was that (along with other provisions) a makeup supply of 2.5 kg/s per unit is needed to ensure an indefinite ECI recall time. Therefore, this was established as the minimum flow requirement for the modification [5].

## 2.2 Flow calculations for conceptual designs

Several design options were considered for providing adequate flow from the ESW System to the PHT System. To determine which of these options could meet the flow requirement, hydraulic modelling was done using PipeFlo software [7], which uses fluid flow equations to analyse a piping system. Three main designs were considered, as shown in Figure 4. All used temporary hoses to provide the necessary connections. Flow models were built using approximate hose lengths and loss coefficients for valves and fittings.

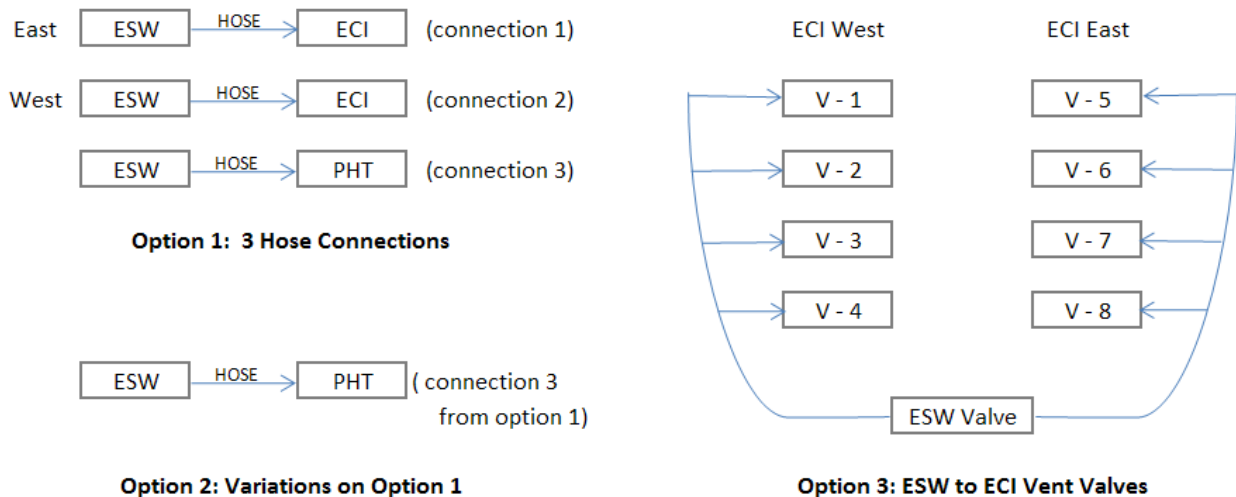

Figure 4: Diagram of Design Options

### 2.2.1 Option 1 – 3 hose connections

Design Option 1 consists of 3 temporary hose connections, as shown in Figure 4. The flowrate calculation for this option estimated 0.6 L/s flow through each ESW to ECI connection and 1.4 L/s flow through the ESW to PHT connection, giving a total flow of 2.6 L/s, under nominal conditions. However, flow tests showed a large variation in flow rates and indicated that overall flow rates were much lower than predicted, suggesting that

some of the smaller ESW valves could be plugged or corroded. Therefore, taking this into account, it was considered advisable to provide additional flow margin to compensate for uncertainty in the flow resistance of the valves.

### 2.2.2 Option 2 – variations on option 1

A number of variations on the original ESW to PHT connection (as shown in Figure 5 and Table 1) were explored to reduce flow restrictions. The ESW to ECI connections remained unchanged.

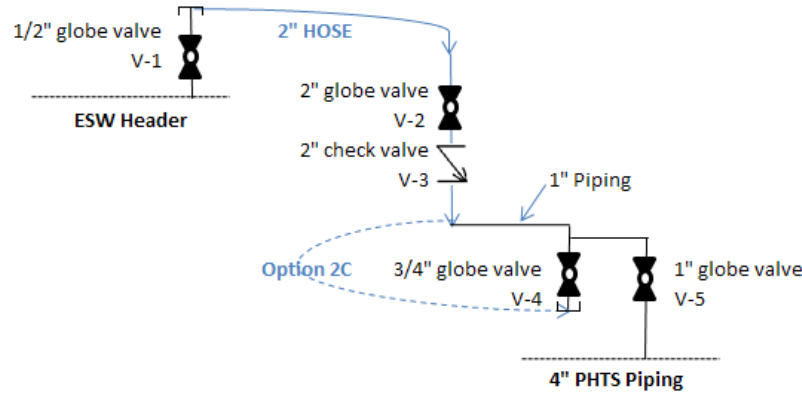

Figure 5: Diagram of ESW to PHT Connection (from Option 1)

Option	Description	Flow Rate (L/s)
2A	V-1 changed to 2" gate valve	2.2
2B	Same as Option 2A, with 1" piping changed to 2"	3.7
2C	Option 2A with hose connected to V-4	2.4
2D	Same as option 2C, but V-4 replaced by new 3/4" gate valve	2.9

Table 1: Flow Rates for Option 2 Variations of ESW to PHT Connection

It was found that Options 2B and 2D would meet the flow requirement, but these were not selected because the necessary modifications to the existing piping and valves would involve performing work in an area of the plant with limited accessibility. OPG also favoured a design option that provided higher flow margins.

### 2.2.3 Option 3 – connection for ESW to ECIS

Option 3 involves connecting one tie-in point on the ESW System (a new 2" valve) to 8 insertion points on the ECIS (existing 3/4" vent valves), as shown in Figure 4. There are two valves in each of the four quadrants of the reactor building in each unit.

The flow rate to each ECI valve was calculated to be 0.67 L/s, assuming 755 kPa(a) pressure in the ESW header, or 0.58 L/s, assuming 600 kPa(a) pressure in the ESW header. This is unaffected by hose routing. Based on all 8 connections being used, the total flow would be 5.3 L/s or 4.7 L/s, depending on the assumed ESW pressure. This option was chosen for the final design because it provides the greatest margin on the flowrate.

The final calculation used elevations, piping and hose configurations, and loss coefficients for valves and fittings based on final design documentation. The flow schematic in Figure 6 shows hose connections, tie-in points, and flow through the ECIS piping to the Reactor Inlet Header (RIH) or Reactor Outlet Header (ROH). The ESW source pressure, originally assumed to be 755 kPa(a) or 600 kPa(a), was modelled as 486 kPa(a) for the final design. The reason for the reduction in the assumed pressure is discussed in the next section. Based on the final calculation, the design is expected to supply 4.0 L/s makeup water to the PHT System.

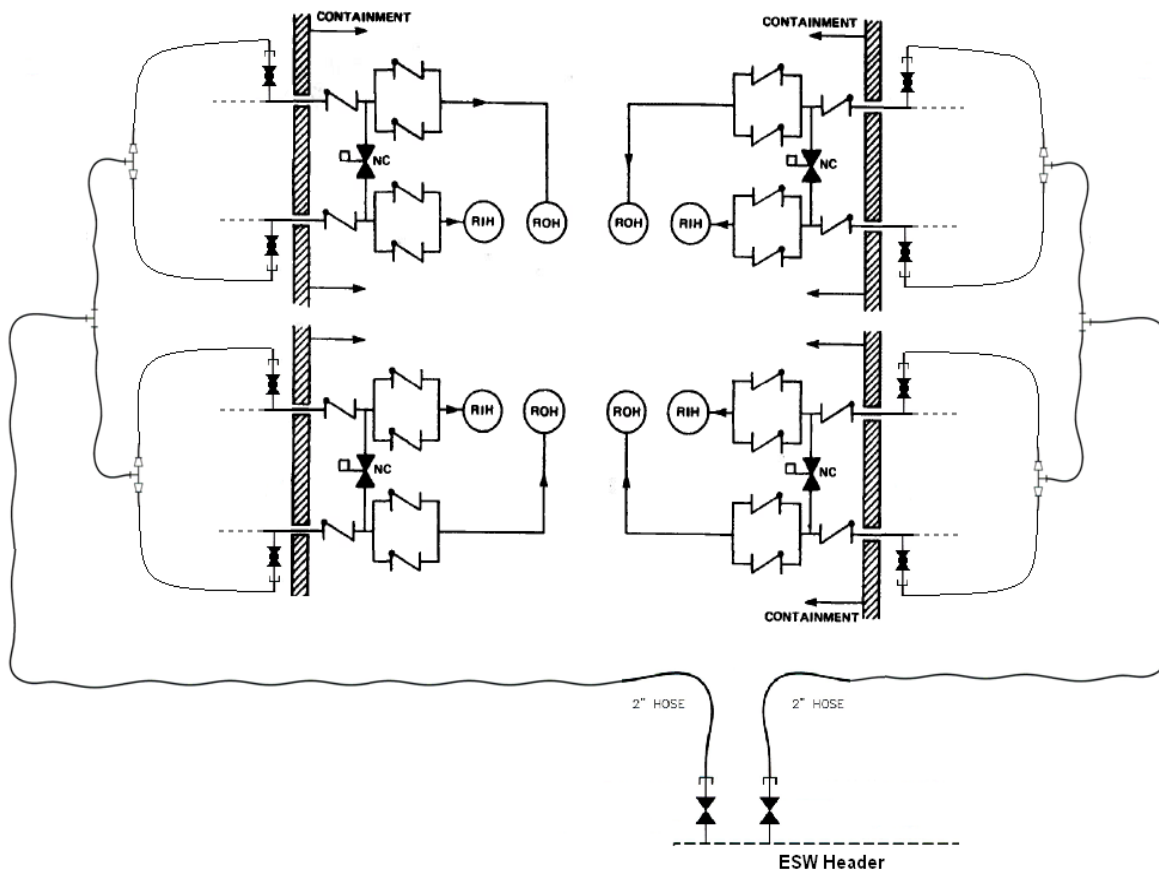

Figure 6: Flow Schematic for Final Design

### 2.3 Post seismic pressure at ESW tie-in point

The post-seismic pressure at the ESW header (source of makeup water) was originally assumed to be 600 kPa(a) (for Option 1 ESW System to ECI System connections), and

755 kPa(a) (for Option 1 ESW System to PHT System connections). For analysis of Option 3, the ESW pressure was originally assumed to be 755 kPa(a), but later lowered to 600 kPa(a) as a conservative measure. However, after selection of Option 3, the ESW network model was revisited and revised to take into account expected loads and post-seismic conditions for the outage, and the post-seismic pressure at the tie-in points was further lowered to 486 kPa(a) [8].

### **3. Seismic requalification of the ESW and ECI piping**

#### **3.1 ESW piping:**

For each reactor unit, two new 2-inch gate valves were installed on the existing 6-inch ESW headers, to provide makeup water to the ECI System piping in the East and West of the reactor building respectively. OPG's in-house computer program, STANPIPES (Version 4 R0 [R-2]), was used to perform two seismic analyses (using the response spectra method), to determine the effect of the added concentrated weight of these valves on the existing seismically qualified system. The results for these analyses confirmed that the requirements of the ASME Power Piping code (ASME B31.1) are still satisfied.

#### **3.2 ECI Piping**

The existing ECIS injection vent piping to be used as the tie-in points are modelled by four separate piping models in STANPIPES, one for each quadrant (N-W, N-E, S-W and S-E). These models were reanalysed to determine the effect of attaching the hoses to the terminal points of the existing permanent piping. Since the STANPIPES program is not capable of modelling materials with the flexibility of a hose, a thin-walled pipe with the weight of the ¾-inch pipe fittings and half of the hose weight between the vent valve and the first hose support was assumed. The hose model was given a free end in order to simulate the dynamic impact of the hose weight. This modelling technique is judged to provide a reasonable approximation of the weight effect of the temporary hose on the permanent piping. The results showed predicted pipe stresses less than 80% of the limits established in the ASME Boiler and Pressure Vessel Code (Section III). For those locations where predicted stresses exceed 50% of ASME allowable limits, the additional predicted stresses due to the change are less than 10% of the original stress values.

From the results, it was concluded that, when the temporary hoses and fittings are added to the ECIS injection vent piping, the requirements of the ASME Boiler and Pressure Vessel Code continue to be met for the loads considered.

### **4. Commissioning**

Although this modification is critical to the outage, full performance testing through the existing ECI and PHT piping is not feasible, because it would dilute the heavy water in the PHTS with light water. Alternative testing methods will be used to confirm that the pressure drops through the hoses predicted by the hydraulic calculation are valid.

## **5. Discussion of design issues**

The likely pressure in the ESW header, during an ECI outage and after a DBE, was not known. There was some debate as to how conservative the estimate should be. Originally, this pressure was estimated to be 755 kPa(a), then reduced to 600kPa(a), and then further reduced to 486 kPa(a) (the most conservative value) in the final calculation. The predicted values were affected by expected loads on the system during the ECI outage window, should a seismic event occur. Prior to any future outages, the assumed ESW pressure will need to be revisited if these conditions are expected to change.

Although not all details are known about the conditions of the flow tests performed for Option 1, the variation in observed ESW pressures and flow rates in these tests suggest that there are undetermined factors affecting consistency of the flow through some of the smaller ESW valves. As this could not be confirmed at the time, it was considered prudent to assume that the flow resistances through these valves could be higher than expected and to allow for a flowrate margin to compensate for this. To improve characterization of the model, the actual resistances of the components in the flow path should be determined to the extent practical, and reconfirmed prior to each outage.

The exact make and model of valves installed in the field varied between units and was difficult to confirm. For example, two models of ¾-inch globe valves (ECI vent valves) were found, each with different loss coefficients. In general, for small valves (i.e. ¾-inch and smaller), the value of the loss coefficient significantly affects the flow calculations. To keep the models simple and conservative, the largest loss coefficient was assumed for all valves of a certain type and size in the flow modelling.

## **6. Conclusions**

This paper details an example of a critical modification required to support a maintenance outage at Darlington NGS, and shows some of the difficulties and uncertainties that must be taken into account in designing a modification that cannot be fully commissioned. Through design review, a Temporary Modification design that was developed for a single occurrence of an outage has been converted to a modification that can be repeated for future outages. Through each successive outage, with more experience, as more information on the key parameters is obtained, the design can be continually improved.

## **7. References**

- [1] Darlington Safety Report: Part 2 – Design Description, OPG Document Number NK38-SR-03500-10001, R002, Section 6.5 – Containment System, December 19, 2007.
- [2] Darlington Safety Report: Part 2 – Design Description, OPG Document Number NK38-SR-03500-10001, R002, Section 6.4 - Emergency Coolant Injection System, December 19, 2007.

- [3] Darlington Safety Report: Part 2 – Design Description, OPG Document Number NK38-SR-03500-10001, R002, Section 5.1 – Heat Transport and Auxiliary Systems, December 19, 2007.
- [4] Darlington Nuclear 1-4 Safety Report: Part 3 – Accident Analysis, OPG Document Number NK38-SR-03500-10002 R002, Section 11.1 – Design Basis Earthquake, October 31, 2006.
- [5] Modification Design Requirements, DNGS: Post Seismic PHT Makeup, OPG Document Number NK38-MDR-33300-10002, R001, December 16, 2008.
- [6] OPG Letter of File, J. Urbanowicz (OPG Reactor Safety), “ECIS Recall Time Calculation for a Postulated DBE Scenario with 1 Square Inch Hole at the Bottom of the Header”, Darlington NGS 2003 Station Containment Outage Support, OPG File Number NK38-03631, May 31, 2002.
- [7] PIPE-FLO Professional 2007 by Engineered Software Inc.
- [8] OPG Letter of File, S. Sethi (OPG Piping Design) to J. Rubin (OPG Station Engineering), “ESW Post Seismic Hydraulic Calculation”, OPG File Number NK38-CORR-72800-0271788-LOF, November 26, 2008.